

SMD Power Inductors SFD3D16T Series

SFD3D16T Series ,Various high power inductors are superior to be high saturation for surface mounting.

Mainly used by power supply for VRT,OA equipment Digital camera,LCD television set notebook PC,partablecommunication equipments,DC/DC converters, etc.

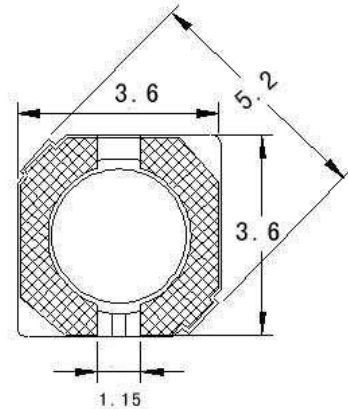
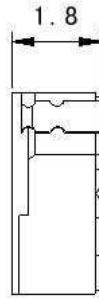
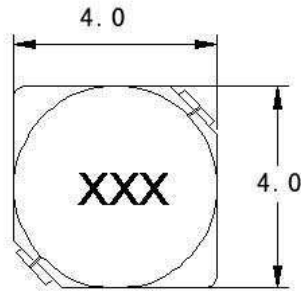

UNIT : mm

1. Inductance tested at 100KHz,0.1V;
2. SRF>13MHz measured using Agilent / HP8753D network Analyzer;
3. Inductance drop = 10% typ. at rated Isat;
4. $\Delta T=40^{\circ}\text{C}$ rise typ. at Irms;
5. Operating temperature range -40°C to $+125^{\circ}\text{C}$;
6. Electrical specifications at $+25^{\circ}\text{C}$;

Packing :
Reel size: 12 mm
Quantity: 2000PCS/Reel

PART NO	L(uH)	DCR max (mΩ)	IDC max (A)	TEST FREQ. (Hz)
SFD3D16T-1R5N	1.5	0.052	1.55	100KHz
SFD3D16T-2R2N	2.2	0.072	1.2	100KHz
SFD3D16T-3R3N	3.3	0.085	1.1	100KHz
SFD3D16T-4R7N	4.7	0.105	0.9	100KHz
SFD3D16T-6R8N	6.8	0.26	0.44	100KHz
SFD3D16T-6R8N	6.8	0.17	0.73	100KHz
SFD3D16T-100N	10	0.21	0.55	100KHz
SFD3D16T-150N	15	0.295	0.45	100KHz
SFD3D16T-220N	22	0.43	0.4	100KHz
SFD3D16T-330N	33	0.675	0.32	100KHz

Special inquiries besides the above common used types can be met on your requirement.

FENFA ELECTRONICS LTD.

Address: Rm 621, 6/F., Shing Yip Industrial Building,
19-21 Shing Yip Street, Kwun Tong, Hong Kong
Tel: (852) 2372 0880, Fax: (852) 2372 0131
E-mail: sales@coilsfenfa.com

<http://www.coilsfenfa.com>
fenfa@coilsfenfa.com

FENFA ELECTRONICS (DONGGUAN) CO., LTD.

Address: Xiakeng Industrial District, Changping Town,
Dongguan City, Guangdong, China
Tel: 86-769-86291668 Fax: 86-769-83999028
Hot line: 86-769-89112128 E-mail: fenfa@coilsfenfa.com