

SMD Power Inductors DM1714 Series

DM1714 Series ,Ultra low cost,Shielded construction,High current rating up to DC 50Amp,High frequency range up to 1.0MHz,Very low DC resistance,Low Noise,RoHS compliant.

Mainly used by Motherboards for laptop and desktop computers,DC/DC converter

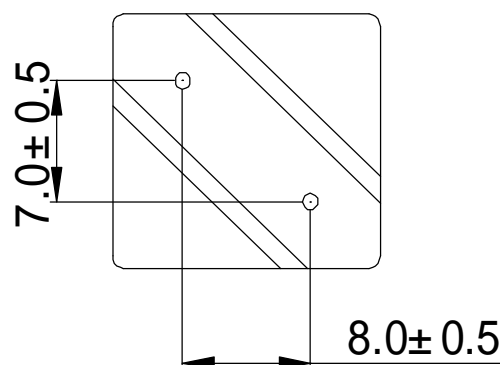
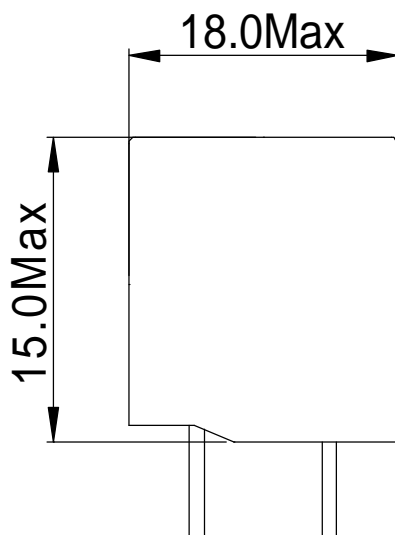

Part Number (品名)	L(uH)	H (高度)	PIN DIM (PIN 径)	DCR(mΩ) (直流阻抗)		I _{rms} DC Current (A) (温升电流)
		MAX	±0.2	TYP	MAX	Typical
DM1714-100M-B-S	10.00	15	1.0	0.52	13	11
DM1714-150M-B-S	15.00	15.0	1.0	0.6	17.00	10.00
DM1714-220M-B-S	22.00	18.0	1.0	0.60	20.00	8
DM1714-330M-B-S	33.00	18.0	1.0	0.60	25.00	6.00

Special inquiries besides the above common used types can be met on your requirement.

<1>I_{rms}: The value of current indicates that the temperature of the coil is increase 40°C (typical).

<2>I_{sat}: The value of current indicates that inductance drops 20%(typical)from its initial value without DC current.

<3>Test condition:Ta= 25°C

<4>Test condition:100KHz 0.1V.

In Bulk Packing

FENFA ELECTRONICS LTD.

Address: Rm 621, 6/F., Shing Yip Industrial Building,
19-21 Shing Yip Street, Kwun Tong, Hong Kong
Tel: (852) 2372 0880, Fax: (852) 2372 0131
E-mail: sales@coilsfenfa.com

<http://www.coilsfenfa.com>
fenfa@coilsfenfa.com

FENFA ELECTRONICS (DONGGUAN) CO., LTD.

Address: Xiakeng Industrial District, Changping Town,
Dongguan City, Guangdong, China
Tel: 86-769-86291668 Fax:86-769-83999028
Hot line: 86-769-89112128 E-mail:fenfa@coilsfenfa.com